

Thermal Cavity Closer

CODE **G242**

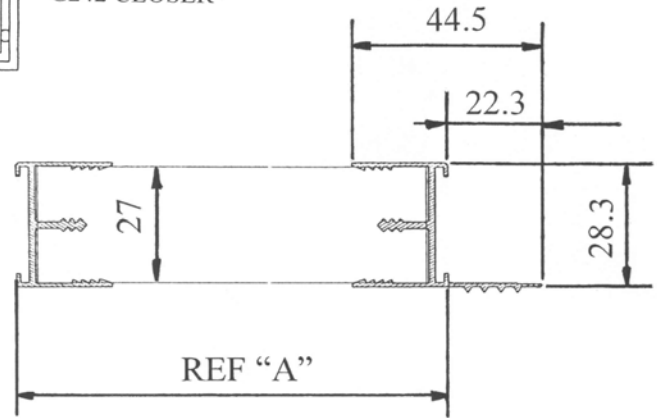
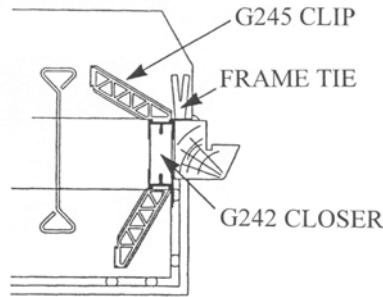
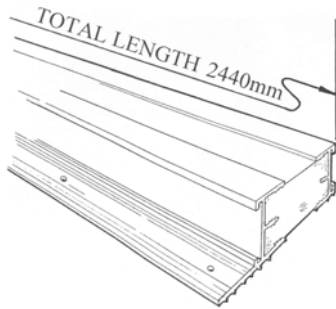

Description:

The Manthorpe G242 Profile Cavity Closer is suitable for use in rebated openings. In this construction the frame is positioned behind the outer leaf and is suitable for use in exposed categories up to and including very serve as defined in table 10 of BS5628 Part 3 that covers all exposure zones in the United Kingdom.

It provides an economical solution to cold bridging problems and is available in a range of sizes to suit all cavity widths it can be easily installed with no special fixing requirements or tools.

The G242 Cavity Closer not only provides a thermal break to the cavity but also acts as an effective vertical DPC barrier.

It meets all current building regulations and achieves the required U value at the reveal of door and window openings when the frames are fixed to allow a 15mm overlap into the cavity. This overlap can be reduced depending on the surrounding construction for further details on how to calculate this required overlap see BRE Information Paper IP 17.

For detailed fitting instructions see product information sheet MBP 8088.

	Extrusion	Styrofoam
COLOUR/S	WHITE	BLUE
PACKING DETAILS	6 lengths per pack	
MATERIAL	UPVC	CFC Free rigid extruded polystyrene insulation block that includes a fire retardant additive
MANUFACTURING PROCESS	Extrusion	Extrusion
K VALUE	0.027 W/mk	
BBA CERTIFICATE NUMBER	96 / 3226	Copies available to request

PRODUCT CODE	DIMENSION REFERENCE "A"	WEIGHT PER PACK
G242/50	50 + 0 – 2mm	7.8 kg
G242/65	65 + 0 – 2mm	8.0 kg
G242/75	75 + 0 – 2mm	8.2 kg
G242/90	90 + 0 – 2mm	8.4 kg
G242/100	100 + 0 – 2mm	8.6 kg

Intermediate sizes up to 150mm to order.

References:

BRE: DIGEST 262
 BRE: Information Paper IP 17
 BSI: BS5250
 DOE: Building Regs L1
 EC: 3093-940 Standard (Styrofoam)
 NHBC: Good Practice Guide
 NHBC: Standards 1995

MANTHORPE BUILDING PRODUCTS LTD
 MANTHORPE HOUSE
 BRITAIN DRIVE
 CODNOR GATE BUSINESS PARK
 RIPLEY
 DERBYSHIRE DE5 3ND

TEL: 01773 514 200
 FAX: 01773 514 262
 EMAIL: sales@manthorpe.co.uk
 WEB: www.manthorpe.co.uk

DRN M.L.W.O

Date 01.08.03

DRG No

Issue

The company maintains a policy of continuous development of its product range and reserves the right to amend the specification without notice.

MPB 8086

A