

Long Block / Stonework Intermediate Tray Right Hand

CODE **GW291 LBS**

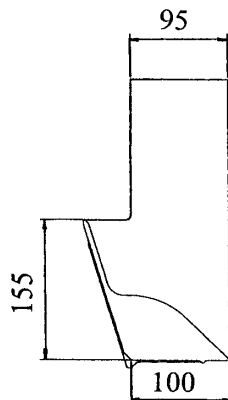

SHORT LEAD
75mm DROP

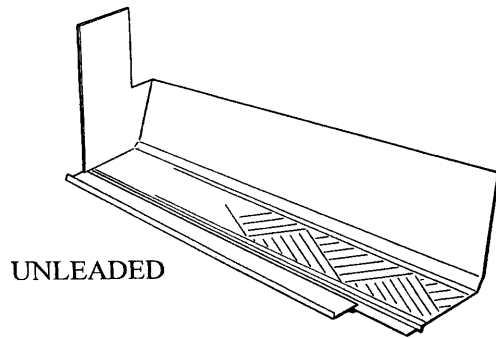
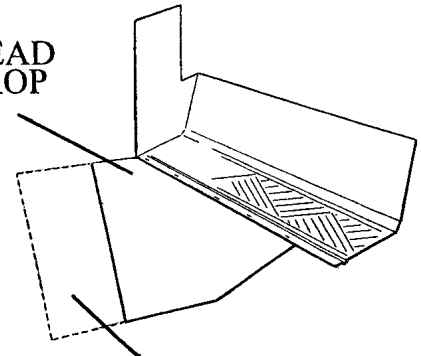

LONG LEAD 75mm DROP
+150mm DROP TO
DRESS OVER TILES

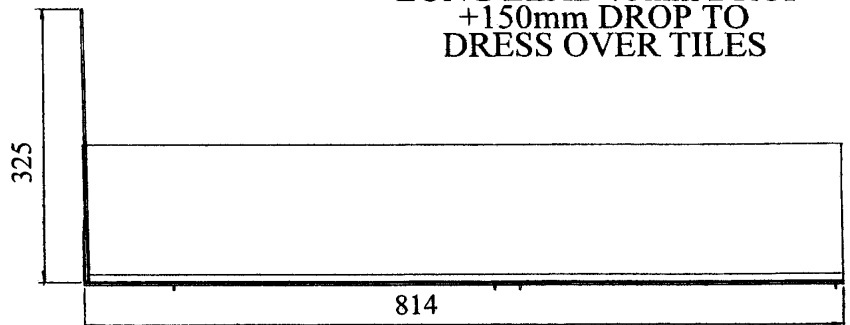

MORTAR CLIP NOT SHOWN

Description:

The GW291 LBS Long Right Hand Intermediate Tray suits low pitches in typically 150mm, 225mm coursing in either stonework or blockwork and has an upstand at one end only. This is so that the water can run out of the tray down the cavity tray system.

The flexible perpend protector attached to the tray prevents driving rain penetrating the outer wall and tracking across the masonry.

The tray has a unique front mortar clip that can be removed at any time once the mortar has set leaving a 25mm deep aperture into which the lead is inserted into and secured with lead wedges.

The GW291 LBS Long Right Hand Intermediate Tray can also be supplied with short or long lead securely attached with staples in either code 4 or code 5 (special order) lead.

Note: - When ordering trays please state roof pitch, course, height, and whether short or long lead is required.

COLOURS	Black
PACKING DETAILS	Packed in 25's in cardboard box (unleaded).
WEIGHT	10.6kg per box (unleaded)
MATERIAL	Polypropylene
MANUFACTURING PROCESS	Injection Molded
SUITABLE FOR CAVITY WIDTHS	50mm to 100mm
SUITABLE FOR PITCHES	17.5 to 34 225mm coursing 12 to 24 150mm coursing
BED SIZE	102.5mm

References:

BRE	:	Building Elements Walls, Windows, Doors
BRE	:	DIGEST 262/380
BSI	:	BS5628
BSI	:	BS8000 Part 3
BSI	:	BS8215
NHBC	:	Standards 6.1

MANTHORPE BUILDING PRODUCTS LTD
MANTHORPE HOUSE
BRITAIN DRIVE
CODNOR GATE BUSINESS PARK
RIPLEY
DERBYSHIRE DE5 3ND

TEL: 01773 514 200
FAX: 01773 514 262
EMAIL:
sales@manthorpe.co.uk
WEB:
www.manthorpe.co.uk

DRN M.L.W.O

Date 01.08.03

DRG No

Issue

The company maintains a policy of continuous development of its product range and reserves the right to amend the specification without notice.

MBP 8130

A